

This drawing involves proprietary design rights of Tyco Electronics Corporation, and all design, manufacture, reproduction, use and sale rights regarding the same are expressly reserved. It is submitted for a specific purpose and the recipient by accepting this drawing, assumes custody and control and agrees to take reasonable precautions; (a) that this drawing will not be copied and reproduced, in whole or in part, or its contents revealed in any manner, or to any person except to meet the purpose for which it was delivered and (b) that any special features peculiar to this design will not be incorporated in other projects without the expressed written permission of Tyco Electronics Corporation.

| REVISIONS | | | |
|--------------|-----|-------------|---------|
| EC | REV | DESCRIPTION | DATE |
| DS1Q-0049-05 | A | NEW RELEASE | 16FEB05 |

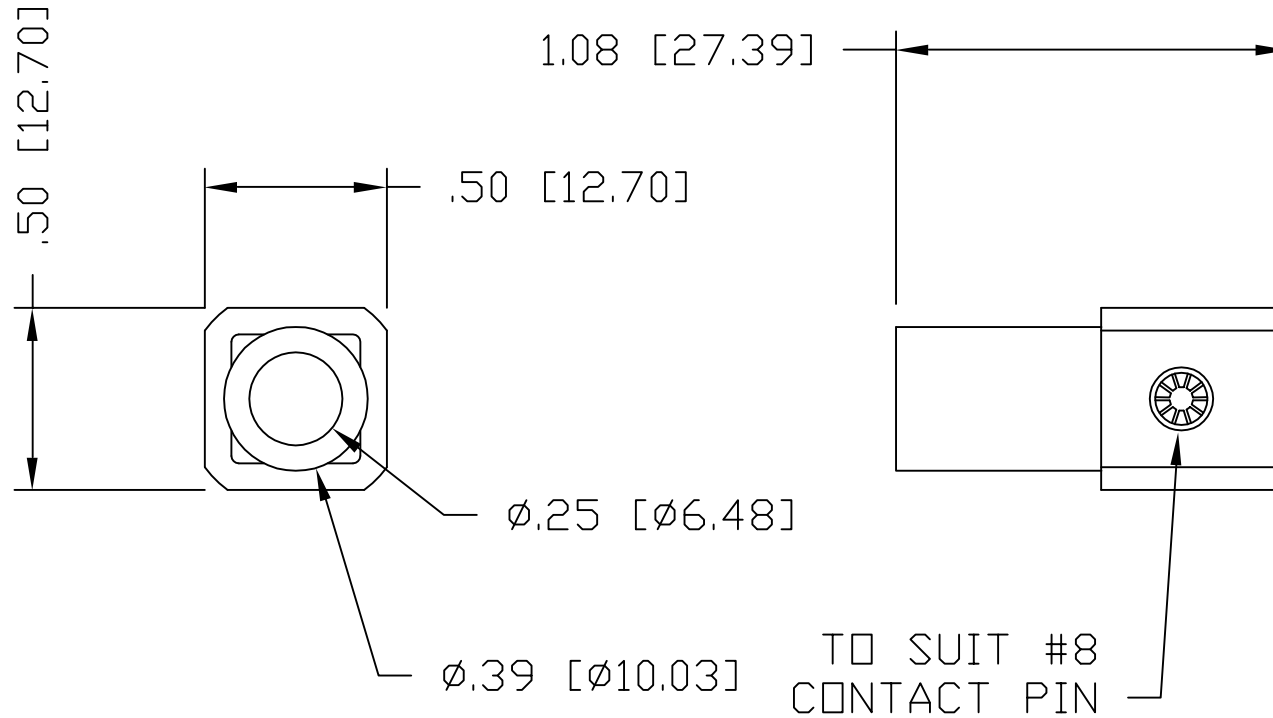

5. FOR TERMINATION, USE THE FOLLOWING EQUIPMENT:

- BENCH CRIMP TOOL - 84C-E031
- INDENTOR DIE SET - 84C-E007
- ASSEMBLY LOCATOR - 84C-E003

4. MATERIAL:

- CROWN CONTACT - BERYLLIUM COPPER ALLOY
- SOCKET HOUSING - TELLURIUM COPPER ALLOY
- INSULATOR - THERMOPLASTIC, UL94V-0, COLOR - SEE TABLE.

| TYCO PN: | COLOUR |
|-----------|--------|
| 1766484-1 | BLACK |
| 1766484-2 | RED |

3. FINISH:

- SOCKET HOUSING - SILVER PLATED.
- CROWN CONTACT - GOLD PLATED.

2. ITEMS PROVIDED TO THIS SPECIFICATION SHALL BE IDENTIFIED ON THE CONTAINER WITH THE FOLLOWING INFORMATION:
PART NUMBER AND DATE CODE OF MANUFACTURE.

1. PART NUMBER CHANGES AND/OR DESIGN CHANGES AFFECTING ITEM INTERCHANGEABILITY REQUIRE PRIOR ELCON APPROVAL AND AUTHORIZATION BY REVISION TO THIS DRAWING.

NOTES: UNLESS OTHERWISE SPECIFIED:

| | | | |
|--|------------------|---------------|--|
| INCH OR INCH (MM) THIRD ANGLE PROJECTION UNLESS OTHERWISE SPECIFIED DIMENSIONS ARE IN INCHES (METRIC) TOLERANCES ANGLES ± .5° DECIMALS .XXX ± .010 [.25] .XX ± .02 [.3] | DRAWN | DATE | Tyco Electronics Corporation Menlo Park, Ca 94025 |
| | M.C.CANT | 16FEB05 | |
| | CHECKED | | TITLE |
| | APPROVED | | JUMPER CROWN SOCKET, RIGHT ANGLE SIZE #8 CROWN SOCKET WITH #6 AWG CRIMP BARREL |
| | APPROVED | | SIZE DWG NUMBER REV. |
| | D. CHAU | 25FEB05 | B C= 1766484 A |
| | DCA APPROVED | | |
| | M. ALIM | 28FEB05 | |
| | ACAD FILE NUMBER | C1766484A.DWG | DWG SCALE 2=1 SH 1 OF 1 |